



**MODEL 8143**  
**SIGNAL SELECTOR**  
**INSTRUCTION MANUAL**

SPECTRACOM CORPORATION  
101 DESPATCH DRIVE  
EAST ROCHESTER, NY 14445-1484

PHONE 585-381-4827  
FAX 585-381-4998

http: [www.spectracomcorp.com](http://www.spectracomcorp.com)

Copyright © 2003 Spectracom Corporation. All rights reserved. Contents of this publication may not be reproduced in any form without the written permission of Spectracom Corporation.

REVISIONS, IF ANY, ARE LOCATED AT THE END OF THE MANUAL

REVISION 2.5 JANUARY 2003

## **WARRANTY**

LIMITED WARRANTY AND WARRANTY CLAIMS: Spectracom warrants each new product manufactured and sold by it to be free from defects in material, workmanship, and construction, except for batteries, fuses, or other material normally consumed in operation that may be contained therein, for five years after shipment to the original purchaser (which period is referred to as the "warranty period"). This warranty shall not apply if the product is used contrary to the instructions in its manual or is otherwise subjected to misuse, abnormal operations, accident or repairs or modifications not performed by Spectracom. Spectracom is not responsible for products that it does not manufacture.

Spectracom's obligation under this warranty is limited to in-factory service and repair, at Spectracom's option, of the product or the component thereof which is found to be defective. If in Spectracom's judgment the defective condition in a Spectracom product is for a cause listed above for which Spectracom is not responsible, Spectracom will make the repairs or replacement of components and charge its then current price, which buyer agrees to pay.

Spectracom shall not have any warranty obligations if the procedure for warranty claims is not followed. Notify Spectracom of the claim with full information as to the claimed defect. Spectracom products shall not be returned unless a return authorization number is issued by Spectracom. Spectracom products must be returned with the description of the claimed defect and identification of the individual to be contacted if additional information is needed. Spectracom products must be returned properly packed with transportation charges prepaid.

EXCEPT FOR THE LIMITED WARRANTY STATED ABOVE, SPECTRACOM DISCLAIMS ALL WARRANTIES OF ANY KIND WITH REGARD TO SPECTRACOM PRODUCTS OR OTHER MATERIALS PROVIDED BY SPECTRACOM, INCLUDING WITHOUT LIMITATION ANY IMPLIED WARRANTY OR MERCHANTABILITY OR FITNESS FOR A PARTICULAR PURPOSE.

Spectracom shall have no liability or responsibility to the original customer or any other party with respect to any liability, loss, or damage caused directly or indirectly by any Spectracom product, material, or software sold or provided by Spectracom, replacement parts or units, or services provided, including but not limited to any interruption of service, excess charges resulting from malfunctions of hardware or software, loss of business or anticipatory profits resulting from the use or operation of the Spectracom product or software, whatsoever or howsoever caused. In no event shall Spectracom be liable for any direct, indirect, special or consequential damages whether the claims are grounded in contract, tort (including negligence), or strict liability.

## **REPAIR AND MAINTENANCE**

Instruments should be returned only upon prior authorization from Spectracom Corporation or its authorized sales and service representative. Warranty repair will be made upon request. Please provide the following information to enable us to serve you efficiently:

1. Model Number and type
2. Serial Number
3. Description of trouble
4. Conditions and hours of use

Upon receipt of this information our service department will send you service data or shipping instructions. Transportation to the factory is to be prepaid by the purchaser.

For assistance contact your nearest Spectracom sales representative.

# **TABLE OF CONTENTS**

## **SECTION 1      INSTALLATION**

1.0	INTRODUCTION .....	1-1
1.1	UNPACKING .....	1-1
1.2	WARRENTY INFORMATION AND PRODUCT SUPPORT .....	1-1
1.3	INPUT POWER .....	1-3
1.4	OPERATING ENVIRONMENT .....	1-3
1.5	PHYSICAL CHARACTERISTICS .....	1-3
1.6	RACK MOUNT INSTALLATION .....	1-5
1.7	EQUIPMENT INTERCONNECT .....	1-5

## **SECTION 2      OPERATION**

2.0	INTRODUCTION .....	2-1
2.1	FRONT PANEL FUNCTIONS .....	2-1
2.2	REAR PANEL CONNECTIONS.....	2-3
2.3	POWER ON.....	2-4

## **SECTION 3      SPECIFICATIONS**

3.0	INTRODUCTION .....	3-1
3.1	OUTPUTS.....	3-1
3.2	INPUTS A & B .....	3-1
3.3	SIGNAL SELECTION .....	3-1
3.4	ALARM OUTPUTS .....	3-1
3.5	ALARM INPUT A .....	3-2
3.6	ALARM INPUT B .....	3-3
3.7	POWER .....	3-3
3.8	MECHANICAL .....	3-4
3.9	OPTIONS.....	3-4
3.10	ORDERING INFORMATION .....	3-4

## **SECTION 4      THEORY OF OPERATION**

4.0	INTRODUCTION .....	4-1
4.1	SIGNAL SELECTOR PCB ASSEMBLY .....	4-8
4.2	AC POWER INPUT (STANDARD).....	4-9
4.3	DC POWER INPUTS - OPTIONS 52 OR 54 .....	4-9
4.4	ALARM OUTPUTS .....	4-9

## **SECTION 5      OPTIONS AND ACCESSORIES**

5.0	INTRODUCTION .....	5-1
5.1	OPTION 06 - 12.8-MHZ INPUTS / OUTPUTS.....	5-1
5.2	OPTION 07 - 5-MHZ INPUTS / OUTPUTS.....	5-1
5.3	OPTION 08 - 1-MHZ INPUTS / OUTPUTS.....	5-1
5.4	OPTION 11 - RACK MOUNT SLIDES .....	5-1
5.5	OPTION 52 - 12 VDC INPUT .....	5-2
5.6	OPTION 54 - 48 VDC INPUT.....	5-2

## **SECTION 6      PARTS LIST**

### **LIST OF ILLUSTRATIONS**

FIGURE 1-1	MODEL 8143 SIGNAL SELECTOR.....	1-3
FIGURE 1-2	OUTLINE DRAWING.....	1-4
FIGURE 1-3	SLIDES, OPTION 11 .....	1-7
FIGURE 2-1	MODEL 8143 FRONT PANEL .....	2-2
FIGURE 2-2	MODEL 8143 REAR PANEL .....	2-3
FIGURE 4-1	BLOCK DIAGRAM.....	4-2
FIGURE 4-2	PRINTED CIRCUIT BOARD SCHEMATIC, (1 OF 3) .....	4-3
	PRINTED CIRCUIT BOARD SCHEMATIC, (2 OF 3) .....	4-4
	PRINTED CIRCUIT BOARD SCHEMATIC, (3 OF 3) .....	4-5
FIGURE 4-3	PRINTED CIRCUIT BOARD ASSEMBLY DRAWING ....	4-6
FIGURE 4-4	MAINFRAME SCHEMATIC DIAGRAM.....	4-7

**MODEL 8143**

**SECTION 1**

**INSTALLATION**

**1.0 INTRODUCTION**

**1.1 UNPACKING**

**1.2 WARRANTY INFORMATION AND PRODUCT  
SUPPORT**

**1.3 INPUT POWER**

**1.4 OPERATING ENVIRONMENT**

**1.5 PHYSICAL CHARACTERISTICS**

**1.6 RACK MOUNT INSTALLATION**

**1.7 EQUIPMENT INTERCONNECT**

# **SECTION 1 INSTALLATION**

## **1.0 INTRODUCTION**

The Spectracom Model 8143 Signal Selector, shown in Figure 1-1, provides failure detection and manual or automatic switchover between two 10-Mhz frequency standards. The selected input is fed through a frequency distribution amplifier to as many as twelve loads.

## **1.1 UNPACKING**

Upon receipt, the carton and its contents should be carefully examined. If there is damage to the carton which results in damage to the unit, contact the carrier immediately. Retain the carton and packing materials in the event the carrier wishes to witness such damage. If you fail to report shipping damage immediately, you may forfeit any claim against the carrier. You should also notify Spectracom Corporation of shipping damage or shortages so that we can help you obtain a replacement or repair the damaged equipment.

Carefully open the shipping carton and remove the packing list from the envelope on the outside of the carton. Check the packing list against the contents to be sure all items have been received, including an owner's manual and ancillary kit.

Retain the carton and packing materials in the event the unit needs to be reshipped or returned to the factory.

## **1.2 WARRANTY INFORMATION AND PRODUCT SUPPORT**

Warranty information is found on the leading pages of this manual. The Model 8183 contains a GPS receiver that is not manufactured by Spectracom Corporation and therefore carries a one-year warranty. In addition, the AC power adapter carries a one-year warranty. Should it become necessary to exercise the warranty, contact Spectracom Corporation to obtain a replacement or service.

Spectracom continuously strives to improve its products and therefore greatly appreciates any and all customer feedback given. Please participate in Spectracom's Customer Satisfaction Survey found on our web site at:

**<http://www.spectracomcorp.com>**

## **Section 1: Installation**

---

The online survey is also used for warranty registration of your new Spectracom products. All completed entries are automatically entered into a monthly prize give away drawing.

Technical support is available by telephone. Please direct any comments or questions regarding application, operation, or service to Spectracom Customer Service Department. Customer Service is available Monday through Friday from 8:30 A. M. to 5:00 P.M. Eastern time.

Telephone Customer Service at: **585-381-4827**.

In addition, please contact customer service to obtain a Return Material Authorization Number (RMA#) before returning any instrument to Spectracom Corporation. Please provide the serial number and failure symptoms. Transportation to the factory is to be prepaid by the customer. After obtaining an RMA# ship the unit back using the following address:

Spectracom Corporation  
Repair Department, RMA# xxxxx  
101 Despatch Drive  
East Rochester, NY 14445

Product support is also available by e-mail. Questions on equipment operation and applications may be e-mailed to Spectracom Sales Support at:

**mailroom@spectracomcorp.com**

Repair or technical questions may be e-mailed to Spectracom Technicians at:

**techsupport@spectracomcorp.com**

Visit our web page for product information, application notes and upgrade notices as they become available at:

**<http://www.spectracomcorp.com>**

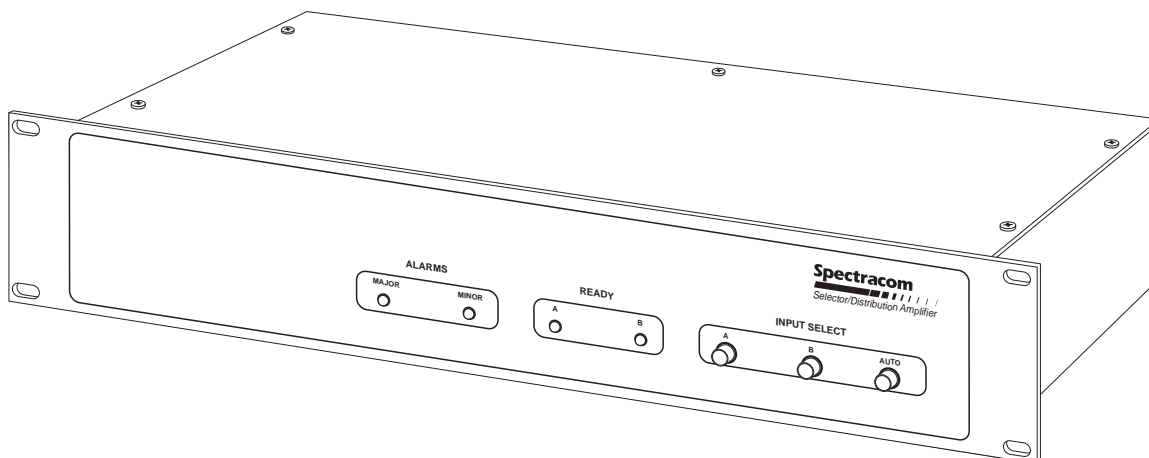

**FIGURE 1-1 MODEL 8143 SIGNAL SELECTOR**

### **1.3 INPUT POWER**

The Model 8143 Signal Selector is operated from 115 VAC power or one of the DC power options shown below. The DC inputs accept either positive or negative polarity and are isolated from chassis ground.

<b>CONFIGURATION</b>	<b>POWER</b>
Standard 8143	115 VAC $\pm$ 15%, 60 Hz, 12 WATTS
Option 52	$\pm$ 12-24 VDC, 10 WATTS
Option 54	$\pm$ 48 VDC, 10 WATTS

### **1.4 OPERATING ENVIRONMENT**

The equipment is designed for operation in a range of -30° to +60°C.

### **1.5 PHYSICAL CHARACTERISTICS**

The Model 8143 Signal Selector physical characteristics are:

Rack Space:	Two rack units (Height 3.50 inches)
Width:	19 inches
Depth:	10 inches
Weight:	6 pounds

## Section 1: Installation

Refer to Figure 1-2 for the Outline Drawing.

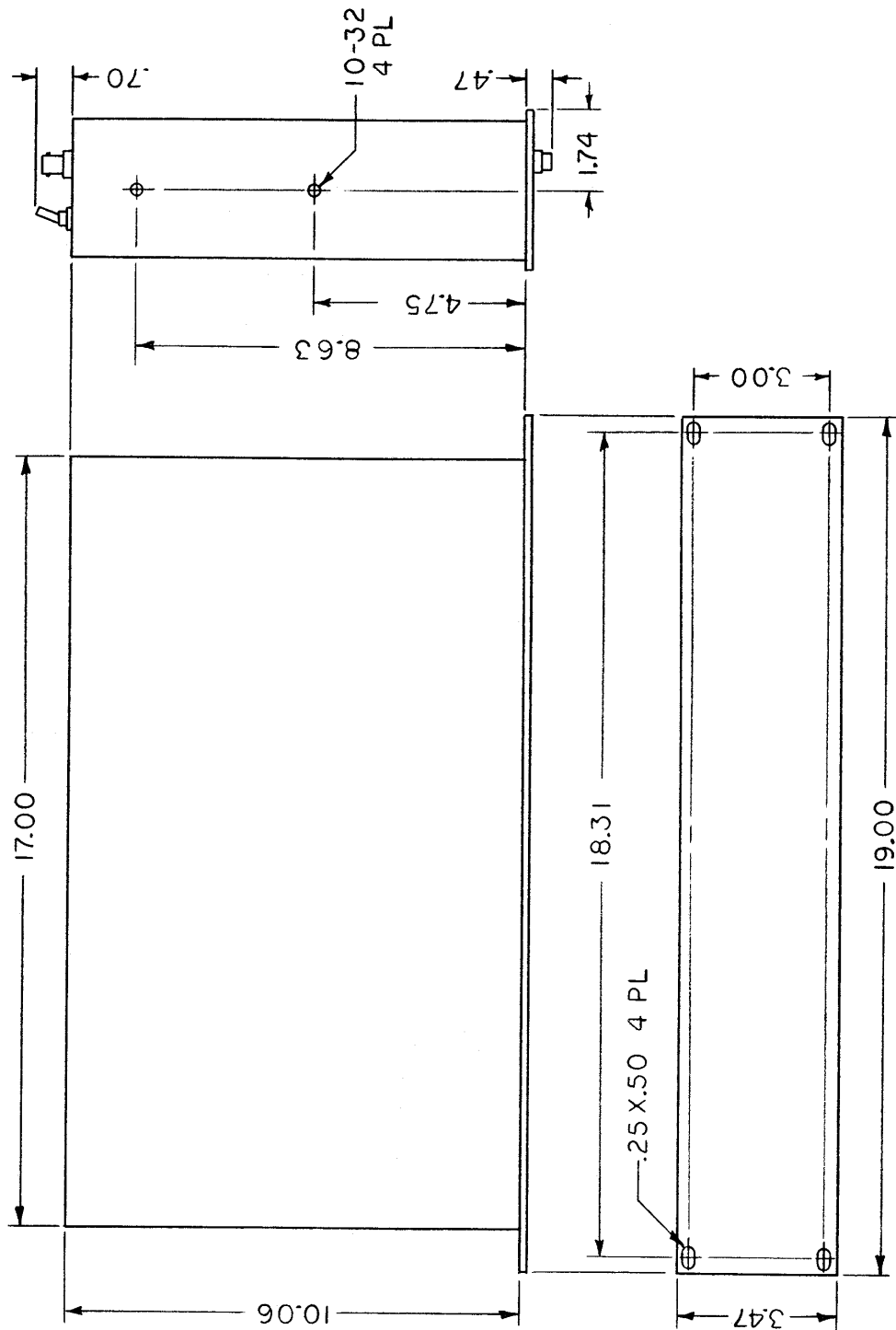

**FIGURE 1-2 OUTLINE DRAWING**

## **1.6 RACK MOUNT INSTALLATION**

There are two methods of mounting the Model 8143 Signal Selector in a standard 19-inch EIA rack.

- A. Rack Mount Installation Without Rack Mount Slide Option 11
  - 1. Locate the desired position in a standard 19-inch EIA rack. Using standard hardware, attach the Model 8143 Signal Selector front panel to the rack mounting rails.
- B. Rack Mount Installation With Rack Mount Slide Option 11

Refer to the installation instruction provided with the Rack Mount Slide Option 11 and Section 5.1, "Rack Mount With Slides".

- 1. Locate the package containing the Option 11 Rack Mount Slide.
- 2. Attach the right and left chassis section of the slides to the Model 8143 Signal Selector.
- 3. Assemble the right and left stationary slide sections to the right and left intermediate slide sections.
- 4. Locate the desired position in a standard 19-inch EIA rack and attach the assembled slides to the front and rear cabinet mounting rails.
- 5. Install the chassis-mounted slide sections on the Model 8143 Signal Selector into the cabinet-mounted slide sections, depressing the lock buttons as required.
- 6. Complete the installation of the Model 8143 by pushing the chassis all the way into the cabinet and fastening the front panel to the cabinet mounting rails. Figure 1-3 shows the Slide installation.

## **1.7 EQUIPMENT INTERCONNECT**

- 1. Make sure the **POWER** control locking toggle switch on the rear panel is in the **OFF** position (down).
- 2. Connect the **REF A INPUT** reference signal to the **REF A INPUT** BNC connector on the rear panel of the unit.
- 3. Connect the **REF B INPUT** reference signal to the **REF B INPUT** BNC connector on the rear panel of the unit.

## ***Section 1: Installation***

---

4. Connect the OUTPUTS to their respective loads.
5. If this is a standard Model 8143, connect the furnished AC line cord from the three-prong **AC INPUT** connector on the rear of the unit to a 115 VAC  $\pm 15\%$ , 60 Hz power source.
6. If this Model 8143 is equipped with Option 52, 12-24 VDC INPUT, use the furnished mating connector to attach the unit to a  $\pm 11-32$  VDC power source.
7. If this Model 8143 is equipped with Option 54, 48 VDC INPUT, use the furnished mating connector to attach the unit to a  $\pm 44.2-66.2$  VDC power source.

The above options (52 or 54) require the positive lead be connected to pin 2 and the negative lead to pin 3. A safety ground is provided on pin 1. To provide redundancy, two DC sources of the same polarity and voltage may be connected simultaneously to the Model 8143. The second power source is connected to pin 4 (GND), pin 5 (POS), and pin 6 (NEG).

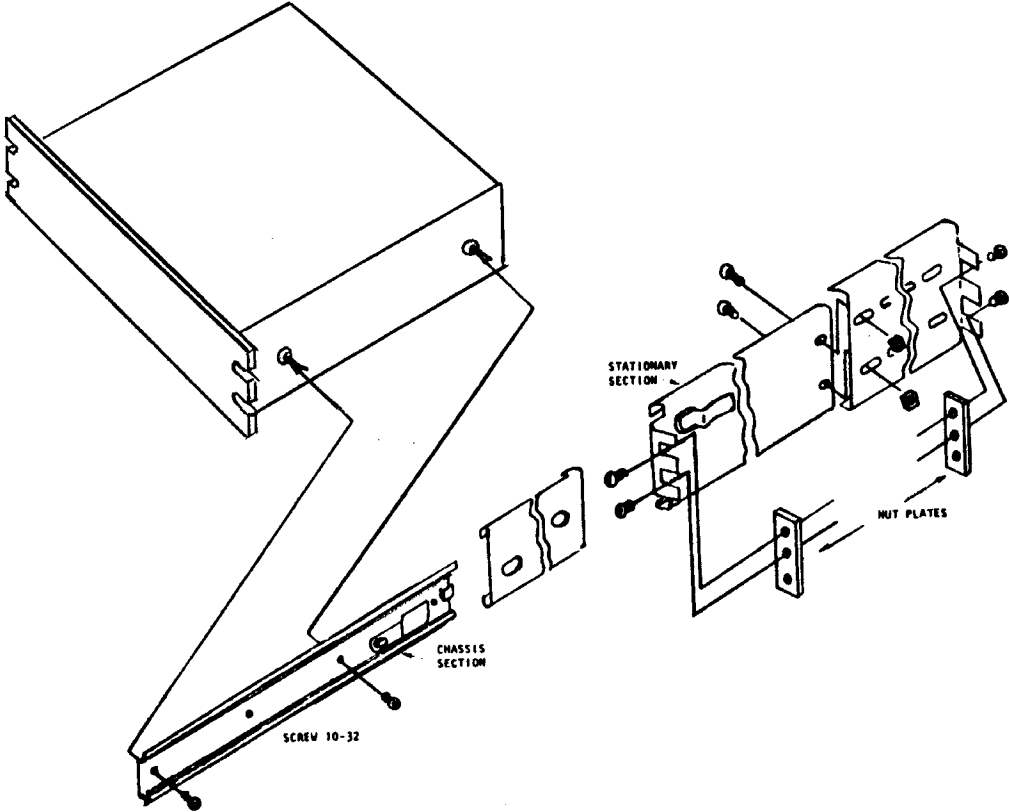

FIGURE 1-3 SLIDES, OPTION 11

**MODEL 8143**

**SECTION 2**

**OPERATION**

**2.0 INTRODUCTION**

**2.1 FRONT PANEL FUNCTIONS**

**2.2 REAR PANEL FUNCTIONS**

**2.3 POWER ON**

# **SECTION 2 OPERATION**

## **2.0 INTRODUCTION**

This section describes the Model 8143 Signal Selector front and rear panel controls and indicators. It then describes the operation of the unit. The Model 8143 provides failure detection and manual or automatic switchover between two 10-MHz frequency standards. The selected input is routed through a frequency distribution amplifier to as many as twelve loads.

## **2.1 FRONT PANEL FUNCTIONS**

Refer to Figure 2-1, Model 8143 Front Panel, and the following paragraphs for a description of the front panel controls and indicators.

### **MAJOR ALARM INDICATOR**

A **MAJOR** alarm is activated when both of the input signals are removed or when alarms are received at both alarm inputs. A MAJOR alarm de-energizes the major alarm relay and illuminates the red Major Alarm indicator.

### **MINOR ALARM INDICATOR**

A **MINOR** alarm is activated when either of the input signals is removed or when an alarm is received at one of the two alarm inputs. A MINOR alarm energizes the minor alarm relay and illuminates the yellow Minor Alarm indicator.

### **INPUT READY A INDICATOR**

Indicates the REF A INPUT signal is present.

### **INPUT READY B INDICATOR**

Indicates the REF B INPUT signal is present.

### **INPUT SELECT A INDICATOR**

Indicates the REF A INPUT signal is selected.

### **INPUT SELECT B INDICATOR**

Indicates the REF B INPUT signal is selected.

**INPUT SELECT AUTO INDICATOR**

Indicates automatic signal select is activated.

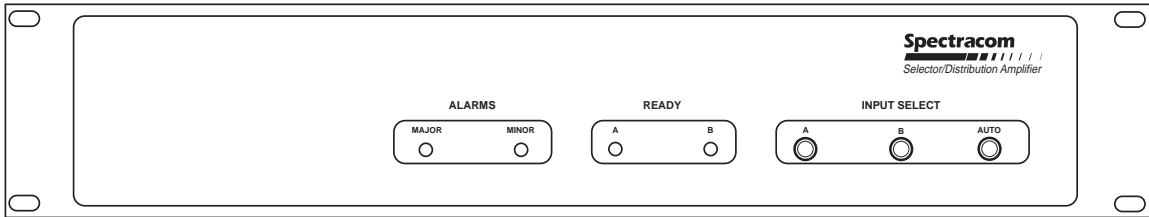

**FIGURE 2-1 8143 FRONT PANEL**

**INPUT SELECT A SWITCH**

Activates manual selection of the REF A INPUT signal.

**INPUT SELECT B SWITCH**

Activates manual selection of the REF B INPUT signal.

**INPUT SELECT AUTO SWITCH**

Activates automatic selection and Ref A Priority. Switchover occurs when the selected signal is removed, or when an alarm input occurs. With automatic selection not activated, switchover is operator-controlled.

## **2.2 REAR PANEL FUNCTIONS**

Refer to Figure 2-2, MODEL 8143 REAR PANEL, to locate the following:

### **ALARM INPUT B**

A detachable terminal strip provides external connections for RS-422 or ground-activated alarm inputs.

### **ALARM INPUT A**

A detachable terminal strip provides external connections for RS-422 or ground-activated alarm inputs.

### **ALARM OUTPUTS**

A detachable terminal strip provides external connections for the MAJOR and MINOR ALARM relay contacts.

### **REF IN B**

This BNC connector is the external connection for the reference B input signal. The REF IN B signal is 10-MHz at 0.10 to 1.0 V rms into 50 ohms.

### **REF IN A**

This BNC connector is the external connection for the reference A input signal. The REF IN A frequency signal is 10 MHz at 0.10 to 1.0 V rms into 50 ohms.

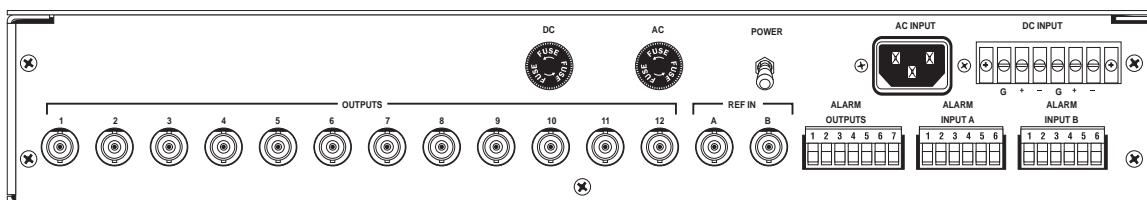

**FIGURE 2-2 843 REAR PANEL**

## **Section 2: Operation**

---

### **OUTPUTS 1 through 12**

These BNC connectors provide the selected reference signal to twelve separate loads. The output level of each OUTPUT is 500 mV rms into 50 ohms.

### **AC INPUT**

A standard three-prong, male AC connector applies power to the unit from the AC line cord.

### **DC INPUT**

This terminal strip is used to apply DC power for one of the two DC Power Options shown below.

Option 52 - 12-24VDC ( $\pm 11$  to 32 VDC), 10 WATTS

Option 54 - 48 VDC ( $\pm 44.2$  to 66.2 VDC), 10 WATTS

## **2.3 POWER ON**

Before applying power:

1. Make sure the REF A INPUT reference input signal (10-MHz) is connected to the **REF A IN** connector.
2. Make sure the REF B INPUT reference input signal (10-MHz) is connected to the **REF B IN** connector.
3. Make sure the proper power source for this Model 8143 Signal Selector is connected per the instructions in Section 1, Paragraph 1.7, Equipment Interconnect Procedure.
4. Make sure the twelve OUTPUTS are connected to loads having 50-ohm impedance, using RG-58/U cable.
5. Turn the locking **POWER** toggle switch on the Model 8143 rear panel to the ON position (up).
6. The Model 8143 Signal Selector is now operational.

**MODEL 8143**

**SECTION 3**

**SPECIFICATIONS**

- 3.0 INTRODUCTION**
- 3.1 OUTPUTS**
- 3.2 INPUTS A & B**
- 3.3 SIGNAL SELECTION**
- 3.4 ALARM OUTPUTS**
- 3.5 ALARM INPUT A**
- 3.6 ALARM INPUT B**
- 3.7 POWER**
- 3.8 MECHANICAL**
- 3.9 OPTIONS**
- 3.10 ORDERING INFORMATION**

# **SECTION 3 SPECIFICATIONS**

## **3.0 INTRODUCTION**

This section contains the detailed electrical and mechanical specifications for the Model 8143 Signal Selector.

## **3.1 OUTPUTS**

Twelve individually buffered outputs from the selected A or B input. Each output is a sine wave provided on a BNC connector at 500 mV rms into 50 ohms. The outputs are ground referenced. Transformer outputs may be isolated by removing a ground jumper at each output.

## **3.2 INPUTS A & B**

Two reference input signals are provided on BNC connectors labeled as the REF IN A and REF IN B signals, respectively. Each signal is a 10-MHz sine wave at 0.10 to 1.0 V rms into 50 ohms.

## **3.3 SIGNAL SELECTION**

With automatic selection activated, switchover occurs when the Ref A signal input is removed, or when an A Alarm input occurs. The unit returns to the Ref A signal input when the Ref A signal returns or the A Alarm input is removed. With automatic selection de-activated, switchover is operator-controlled. Switchover causes a momentary transient in the output reference signal.

## **3.4 ALARM OUTPUTS**

The Model 8143 Signal Selector has two Alarm Outputs: the Major Alarm and the Minor Alarm, described in the following paragraphs.

### **3.4.1 Minor Alarm**

A MINOR alarm is activated when either of the two input signals is removed or when an alarm is received at one of the two alarm inputs (ALARM INPUT A and ALARM INPUT B). A MINOR ALARM energizes the minor alarm relay completing contact between Pins 1 and 3. Pin 2 is open.

## ***Section 3: Specifications***

---

### **3.4.2 Major Alarm**

A MAJOR alarm is activated when both input signals are removed or when alarms are received at both alarm inputs (ALARM INPUT A and ALARM INPUT B). A MAJOR alarm de-energizes the major alarm relay completing contact between Pins 4 and 6. Pin 5 is open.

### **3.5 ALARM INPUT A**

The Alarm Input A is a detachable terminal strip that provides connection for RS-422 or ground-activated alarm inputs.

<b>ALARM INPUT</b>	<b>ALARM CONDITION</b>
Pin 1	A ground on this terminal activates an input alarm.
Pin2 Pin 3	RS-422 input signal levels. If Pin 2 is 0.2 volts less than Pin 3, an input alarm is activated. Input signal range is -12 to +12 volts.
Pin 4	Enables RS-422 input. To enable the RS-422 input connect Pin 4 to Pin 5 (+5 volts).
Pin 5	+5 volts.
Pin 6	Ground.

#### **3.5.1 Alarm Input A -Alternate implementation**

Unit can be configured for normally grounded, open-activated alarm input by connecting a jumper between terminal Pins 4 and 5. Terminal Pin 3 then becomes the alarm input expecting to see a grounded signal. Terminal Pin 6 can be used as the ground source for normally closed contacts.

### **3.6 ALARM INPUT B**

Alarm Input B is a detachable terminal strip that provides connection for RS-422 or ground-activated alarm inputs.

<b>ALARM INPUT</b>	<b>ALARM CONDITION</b>
Pin 1	A ground on this terminal activates an input alarm.
Pin 2 Pin 3	RS-422 input signal levels. If Pin 2 is 0.2 volts less than Pin 3, an input alarm is activated. Input signal range is -12 to +12 volts.
Pin 4	Enables RS-422 input. To enable the RS-422 input connect Pin 4 to Pin 5 (+5 volts).
Pin 5	+5 volts.
Pin 6	Ground.

#### **3.6.1 Alarm Input B -Alternate implementation**

Unit can be configured for normally grounded, open-activated alarm input by connecting a jumper between terminal Pins 4 and 5. Terminal Pin 3 then becomes the alarm input expecting to see a grounded signal. Terminal Pin 6 can be used as the ground source for normally closed contacts.

### **3.7 POWER**

Standard Model 8143	115 VAC $\pm$ 15%, 12 watts, 60 Hz
Option 52	$\pm$ 11 to 32 VDC $\pm$ 20%, 10 watts
Option 54	$\pm$ 55.2 VDC $\pm$ 20%, 10 watts, (48 VDC)

Dual DC inputs at the rear terminal block are internally connected by diode OR. Reverse polarity will not harm the unit.

### ***Section 3: Specifications***

---

#### **3.8 MECHANICAL**

Temperature	-30° to +60°C
Rack Space (Height)	3.50 inches,
Width	19.0 inches, EIA 19" rack
Depth	10.0 inches
Weight	6.0 pounds

#### **3.9 OPTIONS**

Option 06	12.8-MHz Inputs/Outputs
Option 07	5-MHz Inputs/Outputs
Option 08	1-MHz Inputs/Outputs
Option 11	Rack Mount Slides
Option 52	12 to 24 VDC INPUT
Option 54	48 VDC INPUT

#### **3.10 ORDERING INFORMATION**

1. If DC power input is required, specify Option 52 or 54.
2. If rack slides are required, specify Option 11.
3. Configuration is specified by including option numbers in the part number, as shown in the following examples:

8143	(No slide mount, AC power)
8143-52	(No slide mount, 12-24 VDC power)
8143-11-54	(Slide mount, 48 VDC power)

## **MODEL 8143**

### **SECTION 4**

#### **THEORY OF OPERATION**

##### **4.0 INTRODUCTION**

##### **4.1 SIGNAL SELECTOR PCB ASSEMBLY**

##### **4.2 AC POWER INPUT (STANDARD)**

##### **4.3 DC POWER INPUT - OPTIONS 52 OR 54**

##### **4.4 ALARM OUTPUTS**

# **SECTION 4 THEORY OF OPERATION**

## **4.0 INTRODUCTION**

The Model 8143 Signal Selector consists of a single printed circuit board assembly housed in a 3.50 inch high (two rack unit) chassis. The block diagram is shown in Figure 4-1. Fourteen BNC connectors mounted on the rear of the chassis provide interface to the PCB assembly for the two reference input signals and the twelve outputs. Two six-pin and one seven-pin connector provide the interfaces for two alarm inputs and alarm relay contact outputs. A standard AC connector provides for the connection of the AC power source. A six-position terminal strip provides the interface for DC input power options.

A Minor Alarm occurs when either of the input reference signals is absent or when an alarm is received at one of the two alarm inputs. A Major Alarm occurs when both input reference signals are absent or when alarm signals are received at both alarm inputs. A Minor Alarm energizes the minor alarm relay. A Major Alarm de-energizes the major alarm relay. Both alarm relays are Form C, double-pole, double-throw (DPDT) relays with 2A, 30 VDC contacts.

The standard input power configuration for the Model 8143 is a 115 VAC  $\pm 15\%$  60-Hz power source. The unit can be configured with one of two DC input power options. Option 52 accepts an 11 to 32 VDC Input Power source, Option 54 a 48-VDC Input Power source.

Refer to Figure 4-2, Sheets 1-3, Printed Circuit Board Schematic Diagrams. Figure 4-3, Printed Circuit Board Assembly Drawing, shows the component locations. Refer to Figure 4-4 for the Mainframe Schematic.

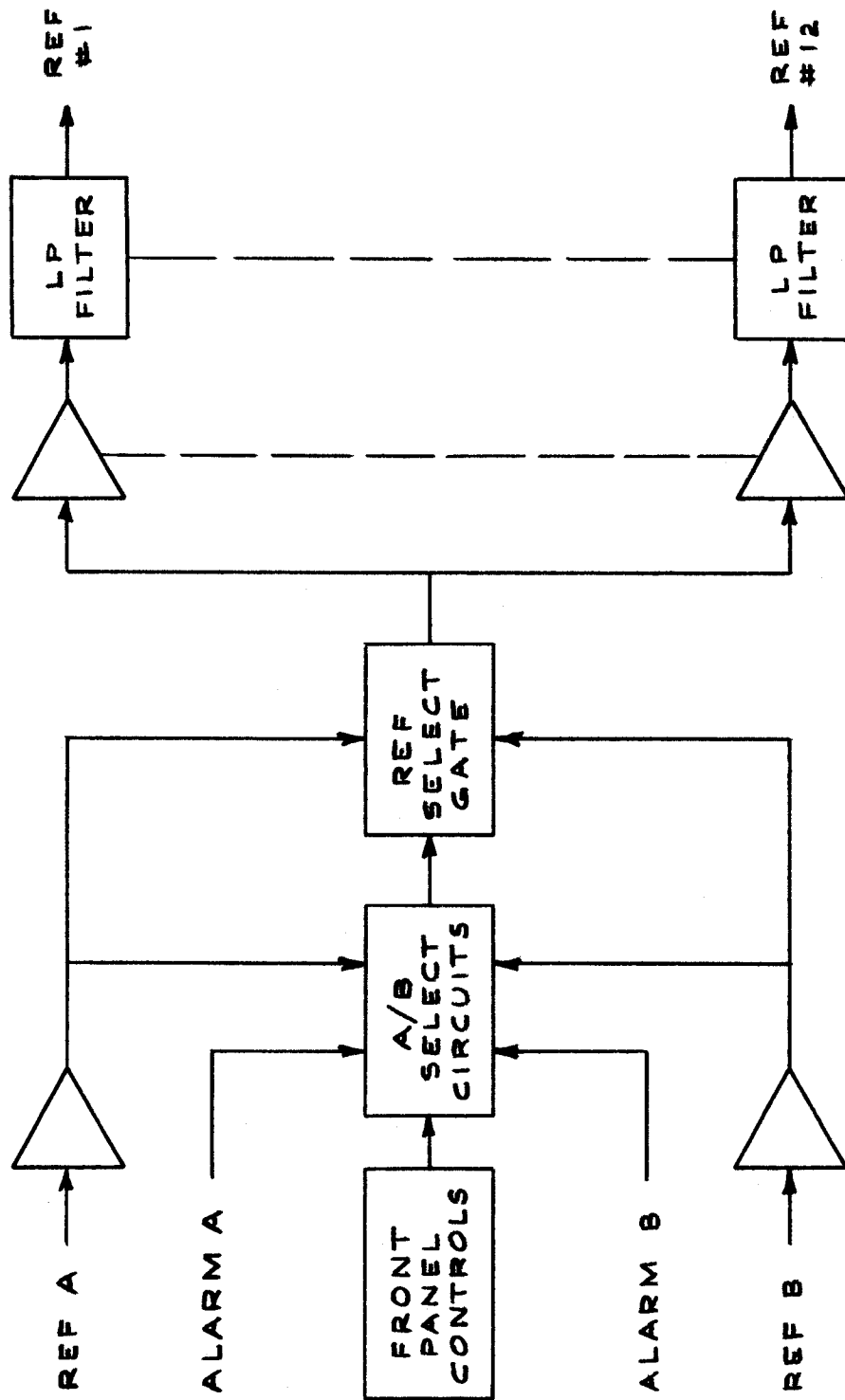

FIGURE 4-1 BLOCK DIAGRAM

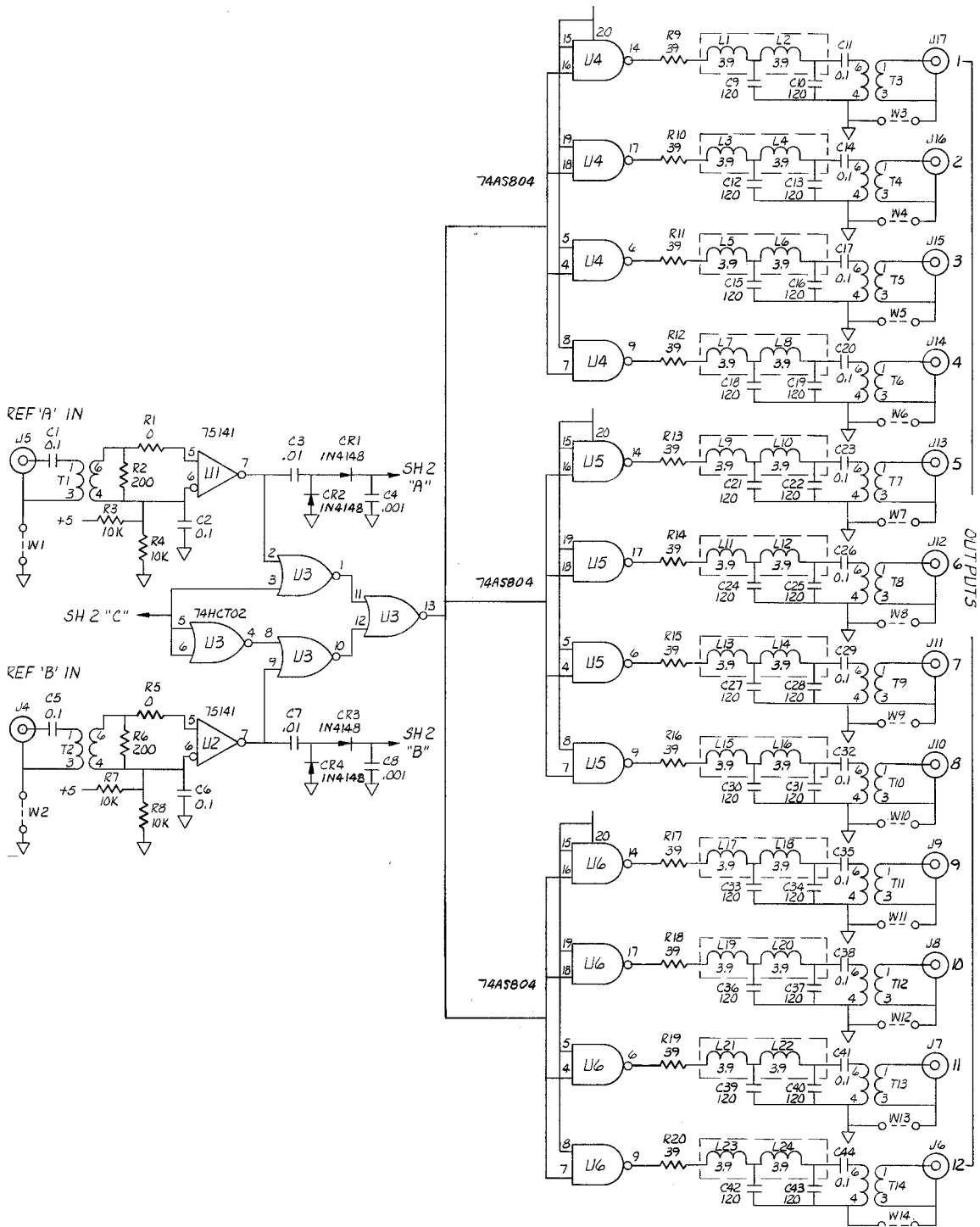
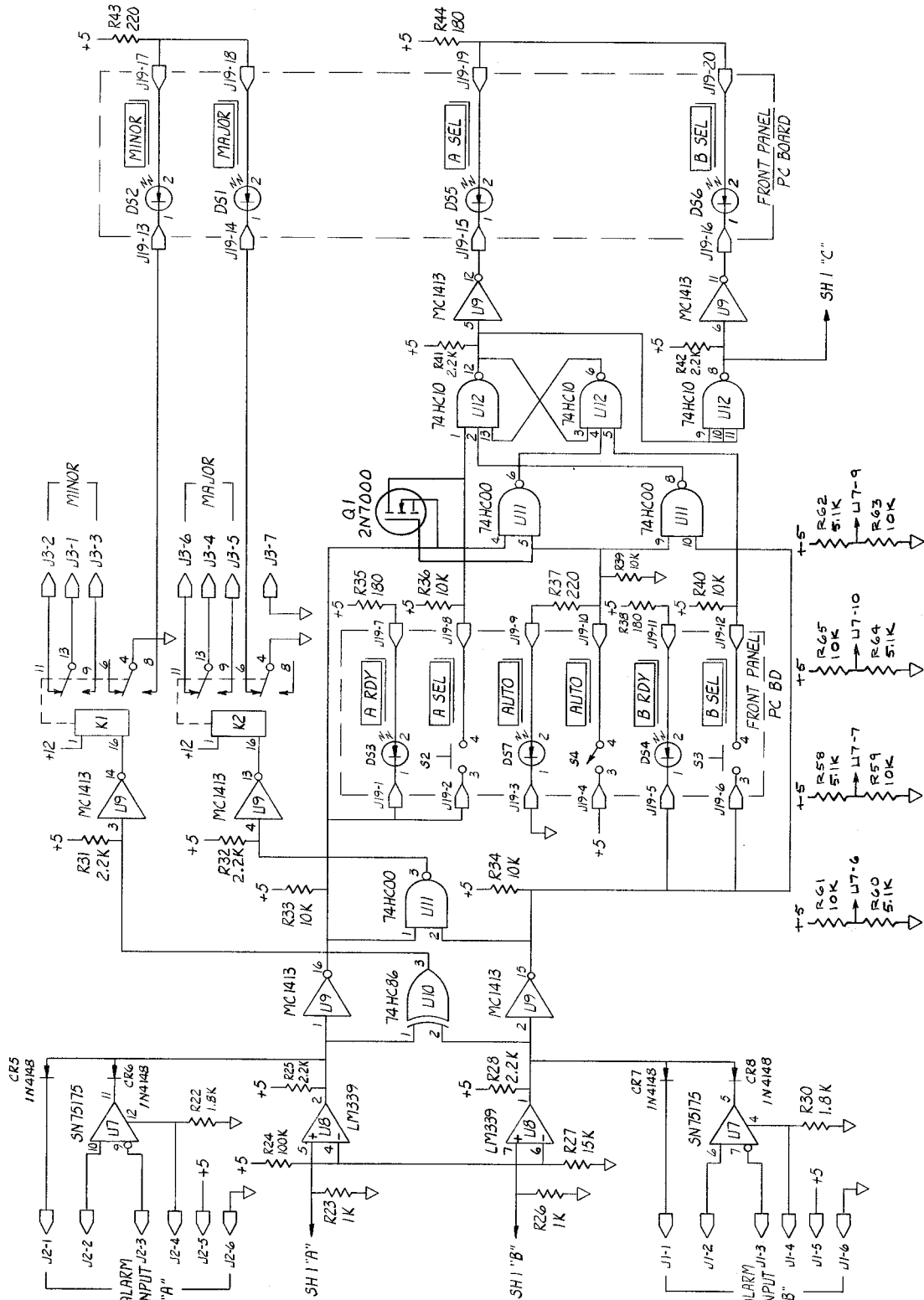

FIGURE 4-2 PRINTED CIRCUIT BOARD SCHEMATIC DIAGRAM  
SHEET 1 OF 3

## Section 4: Theory of Operation



**FIGURE 4-2 PRINTED CIRCUIT BOARD SCHEMATIC DIAGRAM  
SHEET 2 OF 3**

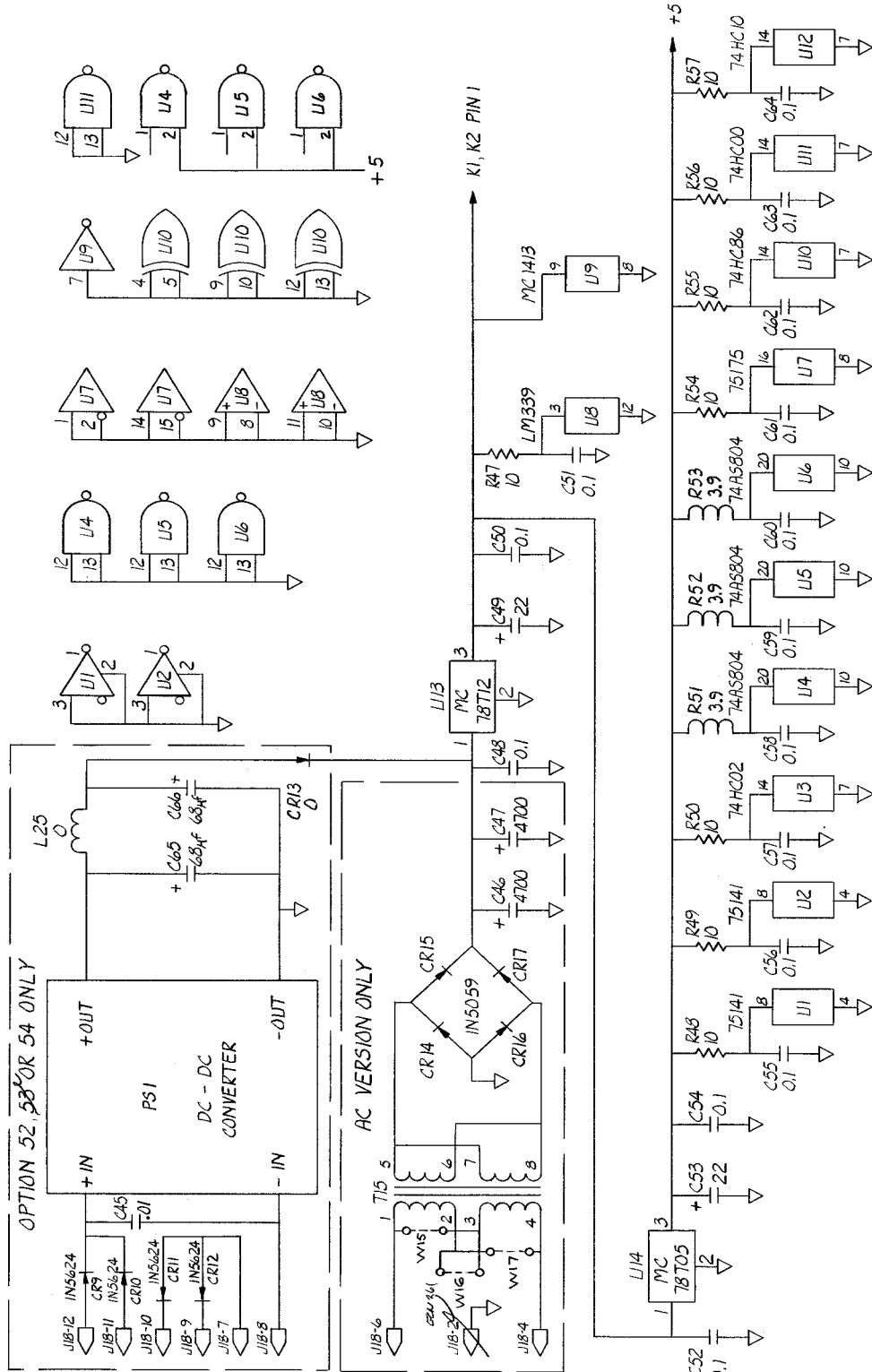

FIGURE 4-2 PRINTED CIRCUIT BOARD SCHEMATIC SHEET 3 OF 3

## Section 4: Theory of Operation

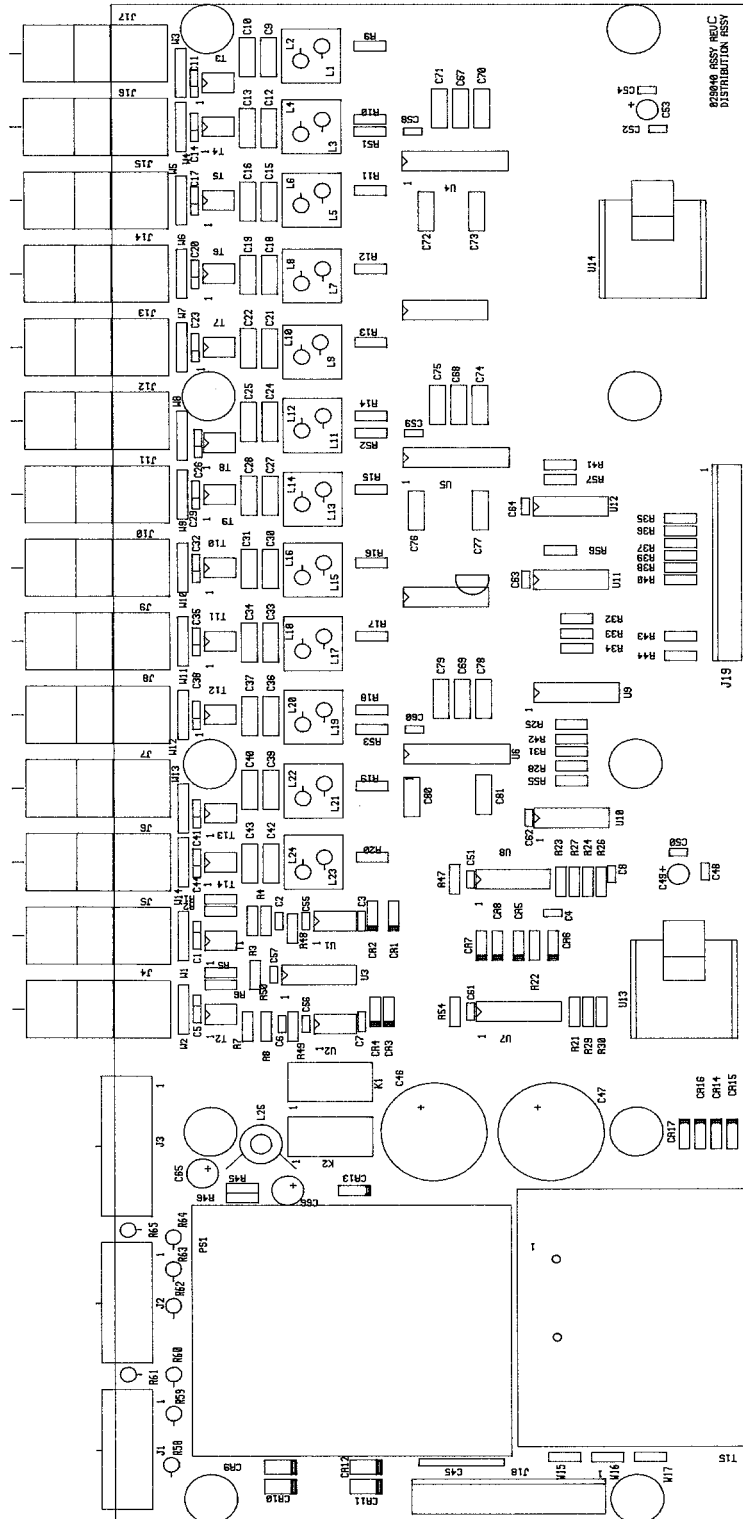

FIGURE 4-3 PRINTED CIRCUIT BOARD ASSEMBLY DRAWING

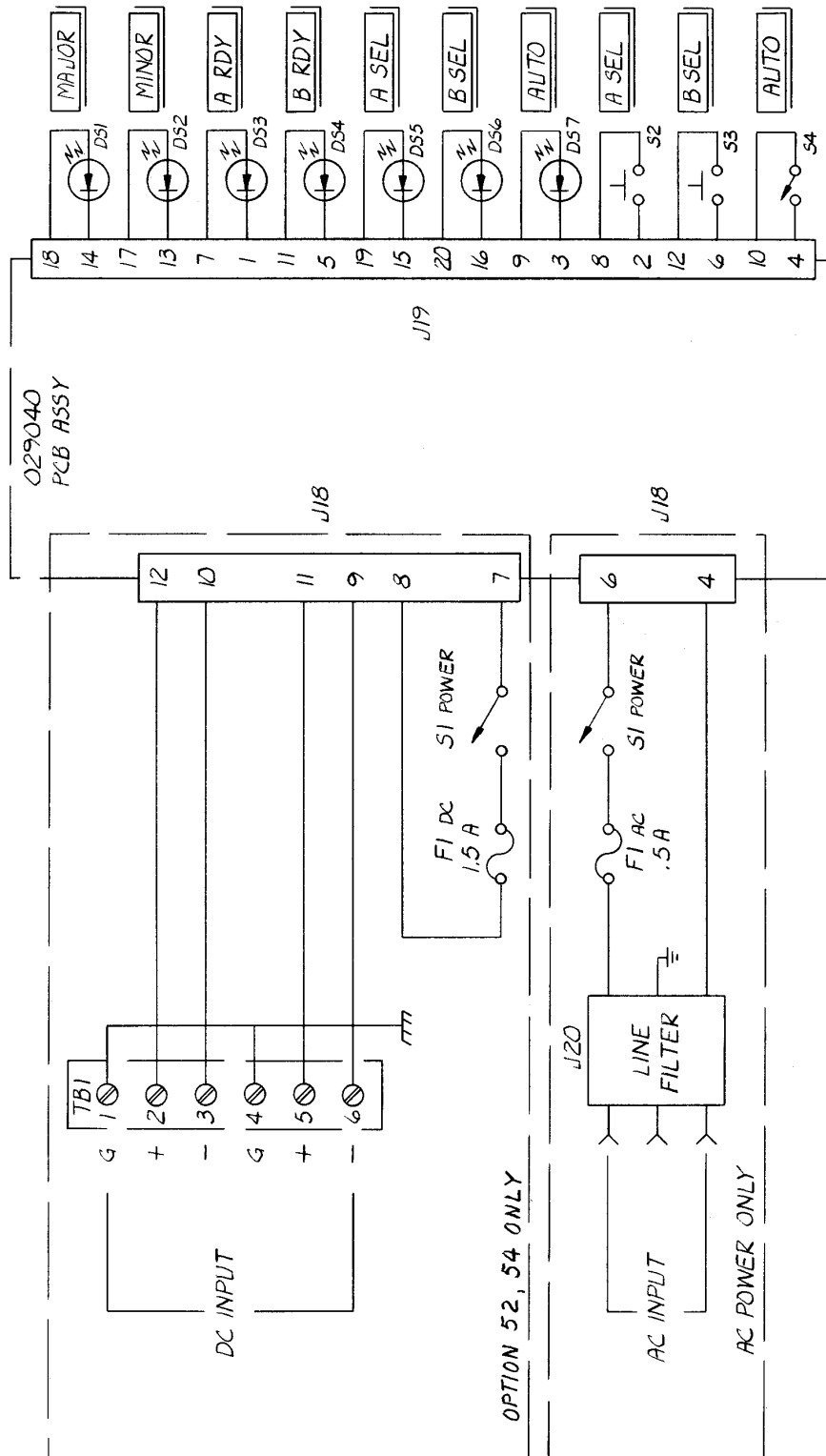

FIGURE 4-4 MAINFRAME SCHEMATIC DIAGRAM

**4.1 SIGNAL SELECTOR PC BOARD ASSEMBLY  
PART NUMBER 029040**

**REF A IN Input Circuitry**

The REF A IN signal at connector J5 is a 10-MHz sine wave at a 0.1 to 1.0 V rms level, capacitor-coupled to the input transformer T1. T1 provides input isolation and impedance matching for the REF A circuitry. The REF A IN signal is applied to line receiver U1, converted to a TTL level and fed to the output distribution circuitry via OR gate U3. The TTL output of U1 is also detected by voltage comparator U8 and its associated circuitry. The output at U8-2 is high when a signal is present.

**REF B Input Circuitry**

The REF B IN signal at connector J4 is a 10-MHz sine wave at 0.1 to 1.0 V rms level capacitor-coupled to the input transformer T2. T2 provides input isolation and impedance matching for the REF B Input circuitry. The REF B IN signal is applied to line receiver U2 where the signal is converted to a TTL level and fed to the output distribution circuitry via OR gate U3. The TTL output of U2 is also detected by voltage comparator U8, and its associated circuitry. The detected output at U8-1 is high when a signal is present.

**Output Circuitry**

The selected reference signal at U3-13 is buffered by line drivers U4, U5 and U6. Each TTL output is converted to a sine wave by filtering.

**Minor Alarm Relay Control Circuitry**

The REF A IN and REF B IN detected outputs drive exclusive OR gate U10, which controls the K1 Minor Alarm relay. If one of the reference signals is missing, the output at U10-3 goes high and is inverted to energize the K1 Minor Alarm Relay. A signal from either the A or B INPUT ALARM will also cause the output of U10-3 to go high, energizing the relay. A Minor Alarm is indicated by a front panel LED and Form C relay contacts provided at the rear panel alarm output connector.

**Major Alarm Relay Control Circuitry**

The detected REF A and REF B signals are inverted to drive NAND gate U11 which controls the Major Alarm relay K2. If both reference signals are missing, or if a signal is detected on both alarm input connectors, the Major Alarm relay is de-energized. A Major Alarm is indicated by a front panel LED and Form C relay contacts provided at the rear panel alarm output connector.

### **Signal Selection Circuitry**

The detected and buffered A and B signals at U9-16 and U9-15 enable the input select switches and drive the input ready LEDs. Two gates in U11 use the ready signals from U9-16 and U9-15, and the input from the auto switch to program the flip-flop comprising two sections of U12, to select a reference signal. The selected signal is indicated by front panel LEDs.

The Select A and Select B switches may be used in the manual mode. A reference that is not ready may not be selected.

### **4.2 AC POWER INPUT (STANDARD)**

The standard unit is provided with an AC input to transformer T15. The output of T15 is rectified, filtered, and fed to U13, a +12 VDC voltage regulator. +12 VDC is supplied to IC chips U8, U9, relays K1 and K2, and to the input of U14, a +5 VDC voltage regulator. +5 VDC is supplied to IC chips U1 through U7, U10 through U12, and to the +5 VDC logic distribution.

### **4.3 DC POWER INPUT - OPTION 52 OR 54**

In each option, dual DC inputs are provided and diode OR'ed into the DC-to-DC converter PS1. The input for Option 52 is 11 to 32 VDC, and for Option 54, 48 VDC. If one DC bus should fail, power is still applied to the DC-to-DC converter. Reverse polarity on the input will not harm the unit. Power is routed through the rear panel fuse F1 and power switch S1 before being applied to the DC-to-DC converter. The output of PS1 is filtered and applied to the +12 VDC distribution system.

### **4.4 ALARM OUTPUTS**

The relay outputs are shown adjacent to connector J3. The Major Alarm relay contacts are brought out on pins 4, 5 and 6. The Minor Alarm relay contacts are brought out on pins 1, 2, and 3.

**MODEL 8143**

**SECTION 5**

**OPTIONS AND ACCESSORIES**

**5.0 INTRODUCTION**

**5.1 OPTION 06 12.8-MHZ INPUTS/ OUTPUTS**

**5.2 OPTION 07 5-MHZ INPUTS/ OUTPUTS**

**5.3 OPTION 08 1-MHZ INPUTS/ OUTPUTS**

**5.4 OPTION 11 RACK MOUNT WITH SLIDES**

**5.5 OPTION 52 12-24 VDC INPUT POWER**

**5.6 OPTION 54 48 VDC INPUT POWER**

# **SECTION 5 OPTIONS AND ACCESSORIES**

## **5.0 INTRODUCTION**

This section describes the options and accessories which are available for the Model 8143 Signal Selector.

### **5.1 OPTION 06 12.8-MHZ INPUTS / OUTPUTS**

Model 8143 equipped with Option 06 operates at 12.8 MHz instead of 10 MHz. All other specifications are unchanged.

### **5.2 OPTION 07 5-MHZ INPUTS / OUTPUTS**

Model 8143 equipped with Option 07 operates at 5 MHz instead of 10 MHz. All other specifications are unchanged.

### **5.3 OPTION 08 1-MHZ INPUTS / OUTPUTS**

Model 8143 equipped with Option 08 operates at 1 MHz instead of 10 MHz. All other specifications are unchanged.

### **5.4 OPTION 11 RACK MOUNT WITH SLIDES**

Refer to installation instructions provided with Option 11, Rack Mount Slides. Both the right and left slides are assembled in the same manner.

1. Install the intermediate section of the slide assembly into the stationary section of the slide assembly as shown in the installation drawing.
2. Attach the end bracket to the stationary section of the slide assembly using the two screws and nut bar provided.
3. Attach the end bracket to the rear cabinet mounting rail using the two screws and nut bar provided.
4. Attach the front of the stationary section to the front cabinet mounting rail using the two screws and nut bar provided.
5. Attach the chassis section of the slide assembly to the chassis of the Model 8143 using the two screws provided.
6. Repeat the same procedure for the slide assembly on the opposite side of the Model 8143.

## **Section 5: Options and Accessories**

---

7. Attach the chassis sections of the slide assemblies into the intermediate section of the slide assemblies until they lock.
8. Install the Model 8143 by releasing the lock buttons on the slide assemblies and pushing the unit all the way into the cabinet.
9. Attach the front panel of the Model 8143 to the cabinet mounting rails.

### **5.5 OPTION 52 - 12-24 VDC INPUT POWER**

Option 52, 12-24 VDC Input Power, is used in place of the standard 115 VAC power input. This option accepts a  $\pm 11$  to 32 VDC input and requires a 2.0 Amp 3AG fuse.

### **5.6 OPTION 54 - 48 VDC INPUT POWER**

Option 54, 48 VDC Input Power, is used in place of the standard 115 VAC power input. This option accepts a 55.2 VDC (48 VDC) input and requires a 1/2 Amp 3AG fuse.

**MODEL 8143**

**SECTION 6**

**PARTS LIST**

## **SECTION 6    PARTS LIST**

### **6.0 INTRODUCTION**

The parts lists on the following pages include mainframe components, printed circuit board assemblies, and PC board components that are replaceable. Refer to the Schematic Diagrams to determine which optional parts are used in the equipment you have. To order a complete PC board assembly, list the PC board number (029040) followed by the appropriate option numbers.

For example, 029040-52 would be a complete PC board with a 12 to 24 VDC input power supply. (Option 52).

## REPLACEABLE PARTS - MAINFRAME

Ref Desig.	Part Number	Description
DS01	DS00042	LED, RED
DS02	DS00044	LED, YELLOW
DS03, DS04	DS00045	LED, GREEN
F001	F001R0	FUSE, 1.0A, 3AG
F001	F00R50	FUSE, 1/2A, 3AG
S001	S00221	SWITCH, SPDT LOCKING LEVER
S002, S003	S00421	SWITCH, MOMENTARY PB
S004	S00422	SWITCH, ALT ACTION PB
TB01	TB00302	TERMINAL BLOCK, 6 POS
XF01	X00049	FUSEHOLDER

## ANCILLARY KIT

Reference Designation	Part Number	Description
0001	W01000	LINE CORD
0002, 0003	P13006	TERM BLOCK, 6 POS
0004	P13007	TERM BLOCK, 7 POS
0005	MAN8143	MANUAL 8143
F001	F002R0	FUSE, 2.0 (OPTION 52 ONLY)
F001	F00R50	FUSE, 1/2A, 3AG (AC POWER AND OPTION 54)

**REPLACEABLE PARTS - PC BOARD ASSEMBLY**

<b>Ref Desig.</b>	<b>Part Number</b>	<b>Description</b>
A1	029040	8143 PC BOARD ASSEMBLY
C001, C002	C26104	CAP, .1 UF 50V CERAMIC MONO
C003	C26103	CAP, .01 UF CERAMIC MONO
C004	C26102	CAP, .001 UF CERAMIC MONO
C005, C006	C26104	CAP, .1 UF 50V CERAMIC MONO
C007	C26103	CAP, .01 UF CERAMIC MONO
C008	C26102	CAP, .001 UF CERAMIC MONO
C009, C010	C05121	CAP, 120PF MICA
C011	C26104	CAP, .1 UF 50V CERAMIC MONO
C012, C013	C05121	CAP, 120PF MICA
C014	C26104	CAP, .1 UF 50V CERAMIC MONO
C015, C016	C05121	CAP, 120PF MICA
C017	C26104	CAP, .1 UF 50V CERAMIC MONO
C018, C019	C05121	CAP, 120PF MICA
C020	C26104	CAP, .1 UF 50V CERAMIC MONO
C021, C022	C05121	CAP, 120PF MICA
C023	C26104	CAP, .1 UF 50V CERAMIC MONO
C024, C025	C05121	CAP, 120PF MICA
C026	C26104	CAP, .1 UF 50V CERAMIC MONO
C027, C028	C05121	CAP, 120PF MICA
C029	C26104	CAP, .1 UF 50V CERAMIC MONO
C030, C031	C05121	CAP, 120PF MICA
C032	C26104	CAP, .1 UF 50V CERAMIC MONO
C033, C034	C05121	CAP, 120PF MICA
C035	C26104	CAP, .1 UF 50V CERAMIC MONO
C036, C037	C05121	CAP, 120PF MICA
C038	C26104	CAP, .1 UF 50V CERAMIC MONO
C039, C040	C05121	CAP, 120PF MICA
C041	C26104	CAP, .1 UF 50V CERAMIC MONO
C042, C043	C05121	CAP, 120PF MICA
C044	C26104	CAP, .1 UF 50V CERAMIC MONO
C045	C00202	CAP, .01 UF 1600V DISC CERAMIC
C046, C047	C08472	CAP, 4700 UF 35V LITIC
C048	C26104	CAP, .1 UF 50V CERAMIC MONO
C049	C07220	CAP, 22 UF 25V LITIC
C050-C052	C26104	CAP, .1 UF 50V CERAMIC MONO
C053	C07220	CAP, 22 UF 25V LITIC
C054-C064	C26104	CAP, .1 UF 50V CERAMIC MONO
C065, C066	C14686	CAP, 68 UF 25V TANT
CR01- CR08	CR04148	DIODE, IN4148

## REPLACEABLE PARTS - PC BOARD ASSEMBLY CONTINUED

A1	029040	8143 PC BOARD ASSEMBLY
Ref Desig.	Part Number	Description
CR09-CR12	CR05624	RECTIFIER,3A,200 PIV
CR13	R01000	JUMPER, 0 OHMS
CR14-CR17	CR05059	RECTIFIER,1A,200 PIV
J001,J002	J13006	SOCKET, 6 PIN PC MOUNT
J003	J13007	SOCKET, 7 PIN PC MOUNT
J004-J017	J12240	RECEPTACLE, BNC, PC MOUNT
J018	J10014	HEADER, 6 PIN
J019	J02020	HEADER, 20 PIN
K001,K002	K00002	RELAY, DPDT
L001 - L024	L023R9	CHOKE, 3.9 UH
L025	R01000	JUMPER, 0 OHMS
PS01	PS00143	DC-DC CONV, 11-32v IN, 15VDC
PS01	PS00117	DC-DC CONV, 36-72VIN, 15VDC
Q001	Q07000	FET, N-CHANNEL, 2N7000
R001	R01000	JUMPER, 0 OHMS
R002	R01201	RES, 200 OHMS 1/4W 5% C.FILM
R003, R004	R01103	RES, 10K OHMS 1/4W 5% C.FILM
R005	R01000	JUMPER, 0 OHMS
R006	R01201	RES, 200 OHMS 1/4W 5% C.FILM
R007, R008	R01103	RES, 10K OHMS 1/4W 5% C.FILM
R009 - R020	R01390	RES, 39 OHMS 1/4W 5% C.FILM
R022	R01182	RES, 1.8K OHMS 1/4W 5% C.FILM
R023	R01102	RES, 1 K OHMS 1/4W 5% C.FILM
R024	R01473	RES, 47K OHMS 1/4W 5% C.FILM
R025	R01222	RES, 2.2K OHMS 1/4W 5% C.FILM
R026	R01102	RES, 1 K OHMS 1/4W 5% C.FILM
R027	R01153	RES, 15K OHMS 1/4W 5% C.FILM
R028	R01222	RES, 2.2K OHMS 1/4W 5% C.FILM
R030	R01182	RES, 1.8K OHMS 1/4W 5% C.FILM
R031, R032	R01222	RES, 2.2K OHMS 1/4W 5% C.FILM
R033, R034	R01103	RES, 10K OHMS 1/4W 5% C.FILM
R035	R01181	RES, 180 OHMS 1/4W 5% C.FILM
R036	R01103	RES, 10K OHMS 1/4W 5% C.FILM
R037	R01151	RES, 150 OHMS 1/4W 5% C.FILM
R038	R01181	RES, 180 OHMS 1/4W 5% C.FILM
R039, R040	R01103	RES, 10K OHMS 1/4W 5% C.FILM

## REPLACEABLE PARTS - PC BOARD ASSEMBLY CONTINUED

A1	029040	8143 PC BOARD ASSEMBLY
Ref. Desig.	Part Number	Description
R041, R042	R01222	RES, 2.2K OHMS 1/4W 5% C.FILM
R043, R044	R01151	RES, 150 OHMS 1/4W 5% C.FILM
R045, R046	R01103	RES, 10K OHMS 1/4W 5% C.FILM
R047 - R050	R01100	RES, 10 OHMS 1/4W 5% C.FILM
R051-R053	L023R9	CHOKE, 3.9 UH
R054- R057	R01100	RES, 10 OHMS 1/4W 5% C.FILM
R058	R01512	RES, 5.1K OHMS 1/4W C. FILM
R059	R01103	RES, 10K OHMS 1/4W 5% C.FILM
R060	R01512	RES, 5.1K OHMS 1/4W C. FILM
R061	R01103	RES, 10K OHMS 1/4W 5% C.FILM
R062	R01512	RES, 5.1K OHMS 1/4W C. FILM
R063	R01103	RES, 10K OHMS 1/4W 5% C.FILM
R064	R01512	RES, 5.1K OHMS 1/4W C. FILM
R065	R01103	RES, 10K OHMS 1/4W 5% C.FILM
T001, T002	T00038	TRANSFORMER, 200:50 OHM
T015	T00041	TRANSFORMER, 28V @ 1.3A
U001,U002	U75141	DUAL LINE RECEIVER, 75141
U003	UHCT02	QUAD 2 INPUT NOR, 74HCT02
U004 - U006	UAS804	HEX NAND DRIVER, 74AS804
U007	U75175	QUAD, RS-422A RECEIVER, 75175
U008	U00339	QUAD COMPARATOR, LM339
U009	U01413	RELAY DRIVER, 1413
U010	U4HC86	QUAD EXCLUSIVE OR, 74HC74
U011	U4HC00	QUAD 2 NAND, 74HC00
U012	U4HC10	TRIPLE 3 INPUT NAND, 74HC10
U013	U07812	REGULATOR, 12V 1.5 AMP, 7812UC
U014	U07805	REGULATOR, 5V 1.5 AMP, TL780-05CKC
W001 - W014	R01000	JUMPER, 0 OHMS

### REPLACEABLE PARTS - PC BOARD ASSEMBLY

THESE COMPONENTS HAVE BEEN SUBSTITUTED ON THE PC BOARD ASSEMBLY TO MODIFY THE EQUIPMENT TO OPTION 06.

<b>Reference Designation</b>	<b>Part Number</b>	<b>Description</b>
C009	C05101	CAP, 100 PF MICA
C010	C05750	CAP, 75 PF MICA
C012	C05101	CAP, 100 PF MICA
C013	C05750	CAP, 75 PF MICA
C015	C05101	CAP, 100 PF MICA
C016	C05750	CAP, 75 PF MICA
C018	C05101	CAP, 100 PF MICA
C019	C05750	CAP, 75 PF MICA
C021	C05101	CAP, 100 PF MICA
C022	C05750	CAP, 75 PF MICA
C024	C05101	CAP, 100 PF MICA
C025	C05750	CAP, 75 PF MICA
C027	C05101	CAP, 100 PF MICA
C028	C05750	CAP, 75 PF MICA
C030	C05101	CAP, 100 PF MICA
C031	C05750	CAP, 75 PF MICA
C033	C05101	CAP, 100 PF MICA
C034	C05750	CAP, 75 PF MICA
C036	C05101	CAP, 100 PF MICA
C037	C05750	CAP, 75 PF MICA
C039	C05101	CAP, 100 PF MICA
C040	C05750	CAP, 75 PF MICA
C042	C05101	CAP, 100 PF MICA
C043	C05750	CAP, 75 PF MICA
L001 - L024	L023R3	CHOKE, 3.3 UH

### REPLACEABLE PARTS - PC BOARD ASSEMBLY

THESE COMPONENTS HAVE BEEN SUBSTITUTED ON THE PC BOARD ASSEMBLY TO MODIFY THE EQUIPMENT TO OPTION 07.

Reference Designation	Part Number	Description
C009	C05241	CAP, 240 PF MICA
C010	C05271	CAP, 270 PF MICA
C012	C05241	CAP, 240 PF MICA
C013	C05271	CAP, 270 PF MICA
C015	C05241	CAP, 240 PF MICA
C016	C05271	CAP, 270 PF MICA
C018	C05241	CAP, 240 PF MICA
C019	C05271	CAP, 270 PF MICA
C021	C05241	CAP, 240 PF MICA
C022	C05271	CAP, 270 PF MICA
C024	C05241	CAP, 240 PF MICA
C025	C05271	CAP, 270 PF MICA
C027	C05241	CAP, 240 PF MICA
C028	C05271	CAP, 270 PF MICA
C030	C05241	CAP, 240 PF MICA
C031	C05271	CAP, 270 PF MICA
C033	C05241	CAP, 240 PF MICA
C034	C05271	CAP, 270 PF MICA
C036	C05241	CAP, 240 PF MICA
C037	C05271	CAP, 270 PF MICA
C039	C05241	CAP, 240 PF MICA
C040	C05271	CAP, 270 PF MICA
C042	C05241	CAP, 240 PF MICA
C043	C05271	CAP, 270 PF MICA
L001 - L024	L028R2	CHOKE, 8.2 UH

### REPLACEABLE PARTS - PC BOARD ASSEMBLY

THESE COMPONENTS HAVE BEEN SUBSTITUTED ON THE PC BOARD ASSEMBLY TO MODIFY THE EQUIPMENT TO OPTION 08.

<b>Reference Designation</b>	<b>Part Number</b>	<b>Description</b>
C009	C05122	CAP, 1200 PF MICA
C010	C05122	CAP, 1200 PF MICA
C012	C05122	CAP, 1200 PF MICA
C013	C05122	CAP, 1200 PF MICA
C015	C05122	CAP, 1200 PF MICA
C016	C05122	CAP, 1200 PF MICA
C018	C05122	CAP, 1200 PF MICA
C019	C05122	CAP, 1200 PF MICA
C021	C05122	CAP, 1200 PF MICA
C022	C05122	CAP, 1200 PF MICA
C024	C05122	CAP, 1200 PF MICA
C025	C05122	CAP, 1200 PF MICA
C027	C05122	CAP, 1200 PF MICA
C028	C05122	CAP, 1200 PF MICA
C030	C05122	CAP, 1200 PF MICA
C031	C05122	CAP, 1200 PF MICA
C033	C05122	CAP, 1200 PF MICA
C034	C05122	CAP, 1200 PF MICA
C036	C05122	CAP, 1200 PF MICA
C037	C05122	CAP, 1200 PF MICA
C039	C05122	CAP, 1200 PF MICA
C040	C05122	CAP, 1200 PF MICA
C042	C05122	CAP, 1200 PF MICA
C043	C05122	CAP, 1200 PF MICA
L001 - L024	L02390	CHOKE, 39 UH